

# COMBILINE



## HARMONIC FILTER

USA INSTRUCTION MANUAL

KEB COMBILINE

Mat.No.
00U0HU0-K084





This page left blank

<b>1.</b>	<b>Safety Instructions .....</b>	<b>4</b>
1.1	General instructions .....	4
1.2	Intended use .....	4
1.3	Electrical connection .....	4
1.4	Personal protection .....	5
<b>2.</b>	<b>Unit Description.....</b>	<b>6</b>
2.1	Part number information.....	6
2.2	Technical data and environmental conditions .....	6
2.3	Rated values for 60Hz series THDI = 8% .....	7
2.4	Description .....	8
2.4.1	International Standards.....	8
2.4.2	Advantages.....	8
2.4.3	Applications.....	9
2.4.4	Reactive-Power Compensation and Resonance Danger Mitigation.....	9
2.4.5	Filter Capacitor Circuit .....	9
2.4.6	Temperature Sensors.....	10
2.4.7	Cooling Fans.....	10
2.5	Unit Dimensions .....	10
<b>3.</b>	<b>Installation NEMA1 Units.....</b>	<b>15</b>
3.1	Inductive Core Installation Instructions .....	15
3.2.1	Harmonic Filter NEMA1 version (-4000 series) .....	16
3.2.2	Harmonic Filter with KEB COMBIVERT R6-S Line Regen Unit.....	16
3.2.3	Harmonic Filter NEMA1 version -40x1 with MMS auxiliary contacts.....	16
3.2.4	Harmonic Filter NEMA1 version -401x with capacitor contactor(s) .....	16
3.3	Temperature Sensors .....	17
3.4	Cooling Fans .....	17
3.5	Example Schematic Diagram .....	18
<b>4.</b>	<b>Example waveforms.....</b>	<b>19</b>
4.1	Voltage and current at the main line .....	19
4.2	Voltage and current with line choke impedance = 3% 480V/60Hz (4% 400V/50Hz) ..	19
4.3	Voltage and current with the harmonic filter THDI < 8% .....	20
<b>5.</b>	<b>Annex .....</b>	<b>21</b>
5.1	Fourier Analysis / Spectrum .....	21
5.2	Formula and Abbreviations .....	21
5.3	Representative Performance Curves .....	22

# Safety Instructions

---

## 1. Safety Instructions

The directions in this chapter must be absolutely observed for the following reasons:

- **Safety for people and machines**
- **Function and susceptibility to faults**
- **Technical inspector acceptance and certification**
- **Guarantee and warranties**

### 1.1 General instructions

	<b>Only Qualified Electrical Technician</b>	All work from the transport, to installation and start-up as well as maintenance may only be done by qualified personnel (IEC 364 and/or CENELEC HD 384 and IEC-Report 664 and note national safety regulations). According to this manual qualified personnel means those who are able to recognise and judge the possible dangers based on their technical training and experience and those with knowledge of the relevant standards and who are familiar with the field of power transmission (VDE 0100, EN 50178, EN 60204 as well as the appropriate regulations for your area).
---	---	--

### 1.2 Intended use

Frequency inverters / servo drives are drive components which are intended for installation into electrical systems or machines. They serve exclusively for step less speed regulation / control of three-phase asynchronous / permanent magnet motors. Use for other purpose is not recommended and may lead to equipment damage.



	<b>Verify Electric Power System</b>	<p>The KEB harmonic filter is to be used for reduction of harmonic current distortion on the main supply network. The filter is a pass through filter connected in the supply line comparable to a standard AC choke with a laminated iron core. An almost sinusoidal current is drawn from the line side of the filter and optimum conditions are created for the inverter or other electrical equipment using a B6 front end rectifier.</p> <p>Operation of the harmonic filter is exclusively permissible when connected to electrical distribution systems in compliance with ANSI C84.1-1995 and IEEE-519-1992! Electrical systems not in compliance can lead to reduction of the filter's effectiveness and also to destruction of the filter module.</p> <p>External reactive power compensation must be limited such that the total electrical network does not become over compensated.</p>
---	-------------------------------------	--

### 1.3 Electrical connection

Before any installation and connection work, the electrical system must be switched off and secured to prevent accidental turn on and exposure to live electrical parts.

	<b>Verify Connection</b>	The harmonic filter must not be energized until it is determined that the installation and connection complies with NFPA-70 or CSA 22.1. Alterations to the harmonic filter are not allowed. The warranty is void if the product is altered or disassembled or operated in contradiction to these instructions.
---	--------------------------	---

1.4 Personal protection

	<p><b>Protect Against Accidental Contact</b></p>	<p>Dangerous voltage can be present at the main connection point of the KEB Harmonic Filter. The filter shall be installed inside a suitable enclosure to prevent accidental contact or unintended contact with live electrical parts.</p> <p>The supplied frequency inverter and the harmonic filter form a technical unit and for this they may not be separated from the mains independently. An exception is when several frequency inverters are used i.e. several KEB COMBIVERT are supplied from one common harmonic filter. If a separate switching off is necessary for this type of application, use a discharge choke or a power contactor with discharging resistor.</p> <p>Otherwise the complete system must be switched off and the following rules are valid.</p>
	<p><b>Note Capacitor Discharge Time</b></p>	<p>Before any installation and connection work, the system must be switched off and secured.</p> <p>The capacitors in the KEB Harmonic filter and connected motor control device may store a charge. Always wait 5 minutes after switch off before working on any electrical connections.</p>
	<p><b>Cyclic Turn ON and Turn OFF</b></p>	<p>With applications requiring the frequency inverter / servo drive to be switched on and off cyclically, maintain an off-time of at least 5 min. If you require shorter cycle times please contact KEB.</p>



**2.3 Rated values for 60Hz series THDI = 8%**

Table 2.2

Part number	17Z1C03-40xx	18Z1C03-40xx	19Z1C03-40xx	22Z1C05-40xx	23Z1C05-40xx	24Z1C05-40xx	25Z1C05-40xx	27Z1C05-40xx	28Z1C05-40xx	29Z1C05-40xx	30Z1C05-40xx
Power Rated [hp]	25	30	40	75	100	125	150	200	250	300	400
Voltage Rated [V]	208(187..229 +/-0V)			480V (432...528 +/- 0V)							
Current Rated [A]	55	69	82	90	115	150	190	230	290	360	400
Voltage Rated [V]	230(207..254 +/-0V)										
Current Rated [A]	62	74	97								
Frequency Rated	60Hz			60Hz							
Power Loss [W]	296	352	480	875	1175	1400	1700	1900	2338	2786	3680
Recommended wire gauge [AWG]	4	4	2	2	2	2/0	3/0	4/0	350 MCM	500 MCM	600 MCM
Recommended wire gauge [mm <sup>2</sup> ]	25	25	35	35	35	70	95	120	185	240	300
Stud Size for Ring Connector <sup>1)</sup> [mm]	M8	M8	M8	M8	M8	M10	M10	M12	M12	M16	M16
Terminal Torque [Nm]	12	12	31	12	12	31	31	31	31	60	60
Ground Stud Size [mm]	M8	M8	M12	M8	M8	M12	M12	M12	M12	M12	M12
Max. Circuit Protection <sup>2)</sup> [A]	95	115	150	130	170	220	280	340	430	540	600
SCCR [kA]	10	10	10	10	10	10	10	10	10	10	10
Manual Motor Starter Current Setting <sup>3)</sup> [A]	25	28	38	36	41	60	70	73/8	65/33	63/63	80/80

1) Ring connectors must be UL listed (ZMVV) devices and must be crimped on with the manufacturers listed crimp tool and die.

2) These values are recommended. A circuit breaker is recommended since it clears all phases simultaneously. However, the actual required branch circuit protection for the connected motor control takes precedence.

3) Protects capacitors. Factory and recommended setting. When two values are given there are two MMS units and refer to the setting of each.

## Unit Description

---

### 2.4 Description

#### 2.4.1 International Standards

The KEB harmonic filter is a new innovative solution, which can be readily included into the electrical system during the planning phase. Given ample physical space in the electrical control cabinet, it could also be added afterward in the field. The harmonic filter provides the user with compliance of growing international power quality standards.

The following standards are met with the use of the KEB harmonic filter:

•	IEEE 519-1992 (USA)
•	G5/4 Engineering Recommendation (GB)
•	EN 61000-3-2 (up to 16A)
•	EN 61000-3-12 (16-75A)
•	EN 61000-3-4
•	EN 12015 (European lift norm)
•	AS 2279 (Australian)
•	COP, supply rules (Hongkong)
•	Quality of Electric Energy Supply, Harmonics in Public Supply Networks (China)

#### 2.4.2 Advantages

The following advantages are given by means of the special design of the KEB COMBILINE harmonic filter:

•	Separate filter and capacitor mounting plate; This enables installation into small spaces as the capacitor mounting can be up to 2 meters away from the filter
•	Overall structure is compact; small space requirements for installation
•	Installation solution ready-to-connect
•	Significant reduction of the capacitive current during no-load operation
•	No tendency for AC or DC voltage oscillation during rapid load change
•	Significantly smaller voltage drop in comparison to line choke
•	Increase inverter lifetime by means of the trapezoidal output voltage and resulting square-wave current
•	Reduction of THDI to $\leq 8\%$ , Given $I_{sc}/I_L \geq 20$
•	Optional THDI $< 5\%$ (special design)
•	Large power range because parallel connection of filter modules is possible. I.e. two units could be used to feed the double input of the KEB W housing inverter.
•	Very high efficiency, due to the use of high grade steel and high frequency coil winding system
•	Easier mounting compared to a trap filter
•	Damping against oscillation on main line
•	3 phase current protection device for capacitors prevents voltage imbalance in case of activation
•	3 phase UL listed high harmonic capacitors for increased life and reliability



2.4.3 Applications

The KEB COMBILINE Harmonic Filter can be used to reduce the value of THDI to a level  $\leq 8\%$ . The conditions required for this assume the ratio of short circuit current to load current ( $I_{sc}/I_L$ ) is 20 or greater, the maximum pre-distortion of the voltage is not greater than 2%, and the filter is operating at its rated current value.

Under all other conditions the THDI value is still greatly reduced and will none the less provide great benefit to the building power system.

Applications:

•	To achieve compliance with power quality standards
•	Used in place of a line choke to provide smaller voltage drop - results in increases motor torque.
•	Reduction of effective input current to the motor control. Reactive power (kVAR) is greatly reduced, eliminating the need to oversize upstream devices, transformers, power generators, etc.
•	Protection of motor control against voltage spikes or irregularities on the main line
•	Reduction of load on "weak" electrical systems
•	Effectively triples DC bus capacitor lifetime
•	Can be equipped with a synchronization module for use with the R6-S Line Regenerative unit

2.4.4 Reactive-Power Compensation and Resonance Danger Mitigation

Reactive-power compensation equipment is used by the utility companies to compensate for lagging power factor on the utility grid. As these systems automatically adjust against the load on the grid, voltage transients can be created. These transients occur at the medium voltage (MV) level and are easily transferred down to the low voltage (LV) level which most factories and buildings operate at. These can be especially troublesome when the utility is still using capacitor only compensation. The transients can excite the resonance of the building power system resulting in unintended shut down of equipment or worse destruction of equipment. Whether or not the facility has good power quality does not determine the risk factor for system resonance. It is primarily determined by the size of the feed transformer from MV to LV and the level of capacitive load within the facility. Larger transformers provide low impedance electrical systems to the facility. These low impedance systems are more prone to resonate than high impedance systems. As a result capacitive loads (leading PF) within the facility must be minimized.

Therefore it is important to select a harmonic filter such as the KEB COMBILINE filter. Due to the unique KEB filter design, the amount of capacitance and the relative level of capacitive current at no load is much lower than with competitive filters. The result is that the use of the KEB filter reduces the risk of resonance danger.

2.4.5 Filter Capacitor Circuit

The capacitors used in the KEB COMBILINE filter are high performance AC film capacitors. They are designed for long life and to endure the potential voltages which occur naturally on the main line. The capacitor circuit is protected using a 3 phase manual motor starter. These device were chosen specifically to provide short circuit protection as well as overload protection for the capacitors. Most important, the device is a 3 phase protection device and in the event that a fault occurs, all three phases to the capacitors are switched off. Many competitive filters utilize multiple single phase fuses as capacitor protection. In the event one fuse opens, the capacitor bank becomes unbalanced and almost immediately the harmonic distortion will increase to levels greatly above the limits. In extreme cases an unbalanced capacitor bank can increase the ripple on the DC bus of the connected VFD and cause the VFD to fail prematurely.

The MMS units may be optionally provided with auxiliary contacts and signal contacts. The auxiliary contacts confirm the position of the ON/OFF switch and additionally indicate the MMS unit has tripped. In larger units with more than one MMS unit the contact should be wired together to provide complete status indication to the machine control.

## Unit Description

In some cases it may be required to disconnect the capacitors during no load idle periods. In this case the KEB COMBILINE FILTER can be supplied with contactor(s) installed in the capacitor circuit(s). The contactors must be controlled by the machine control unit and shall only be allowed to change states, switch ON or switch OFF, when the connected VFD is disabled. The contactor(s) have 120VAC coils and should be driven from a pilot control relay. Auxiliary contacts on the contactor(s) can be used to monitor the status of the contactor and to synchronize the enabling of the VFD.

### 2.4.6 Temperature Sensors

The KEB COMBILINE Filter is delivered as standard with temperature sensors which can be used to monitor the temperature of the windings. The first sensor T1/T2 is a normally closed cut out switch which opens in the event the windings become too hot. Normally this should only occur if the filter is overloaded for extended periods of time, or the ambient conditions are such that the filter is overheating. The second sensor T3/T4, is a KTY type sensor which can provide a linear temperature which is directly proportional to the actual winding temperature. This sensor can be directly to KEB VFDs or KTY inputs on machine controls. The advantage with this sensor is that it can be used to provide feedback about an imminent overheat condition. In critical systems, rather than simply shutting down the system, the machine control can decide to reduce the system load in order to reduce the temperature and keep the system running. This sensor is only installed on the larger units 75hp and above. Finally the last sensor is a normally open temperature sensor which switches on when the windings reach 100C. This sensor is used internally to switch the cabinet cooling fans ON and OFF.

### 2.4.7 Cooling Fans

The larger filters size 22 and greater require forced cooling across the filter core. The fans are powered directly from the 480V supply and controlled via internal temperature sensors. Care must be taken not to obstruct the fans. With the system operational and under full load, the fans should switch on within 30 minutes of operation.

## 2.5 Unit Dimensions

Harmonic Filter Core Dimensions NEMA 1			
Part number	Voltage	HP	Figures
17Z1C03-40xx	230	25	2.5.1, 2.5.2, 2.5.3, 2.5.4
18Z1C03-40xx	230	30	2.5.1, 2.5.2, 2.5.3, 2.5.4
19Z1C03-40xx	230	40	2.5.1, 2.5.2, 2.5.3, 2.5.4
22Z1C05-40xx	480	75	2.5.1, 2.5.2, 2.5.3, 2.5.4
23Z1C05-40xx	480	100	2.5.1, 2.5.2, 2.5.3, 2.5.4
24Z1C05-40xx	480	125	2.5.1, 2.5.2, 2.5.3, 2.5.4
25Z1C05-40xx	480	150	2.5.1, 2.5.2, 2.5.3, 2.5.4
27Z1C05-40xx	480	200	2.5.5, 2.5.6, 2.5.7, 2.5.8
28Z1C05-40xx	480	250	2.5.5, 2.5.6, 2.5.7, 2.5.8
29Z1C05-40xx	480	300	2.5.5, 2.5.6, 2.5.7, 2.5.8
30Z1C05-40xx	480	400	2.5.5, 2.5.6, 2.5.7, 2.5.8

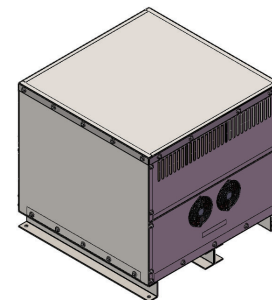
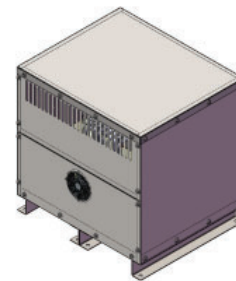

Figure 2.5.1 - Front View - dimensions mm [in]

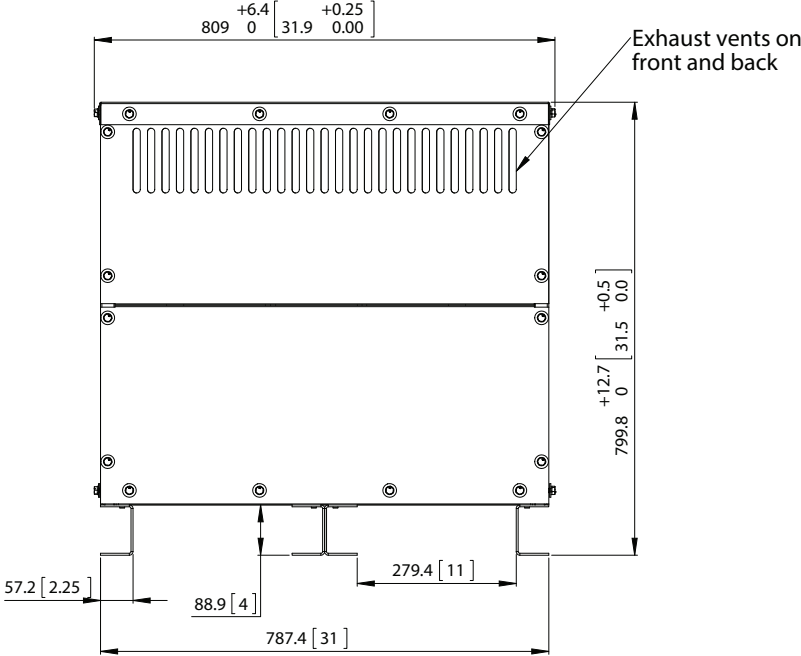
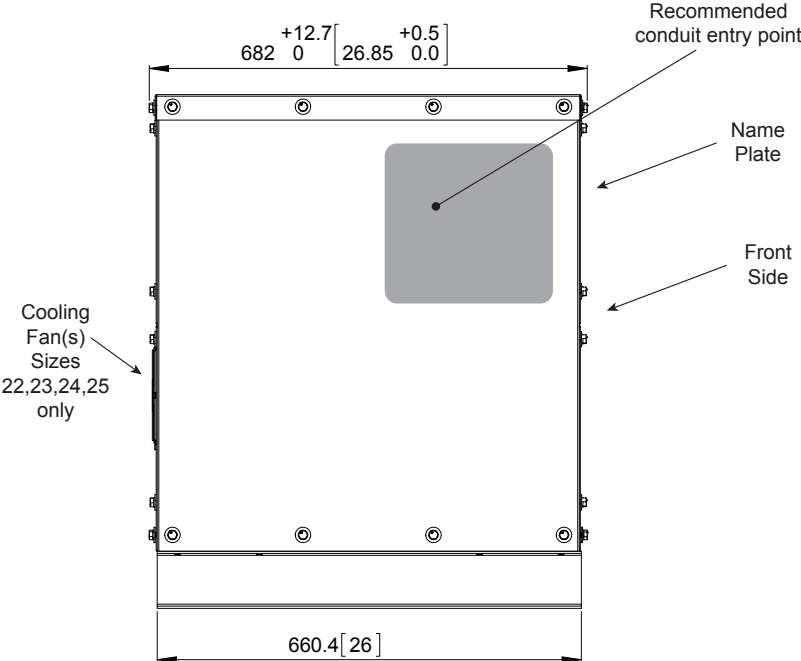

Figure 2.5.2 - Side View - dimensions mm [in]



# Unit Description

Figure 2.5.3 - Bottom View - dimensions mm [in]

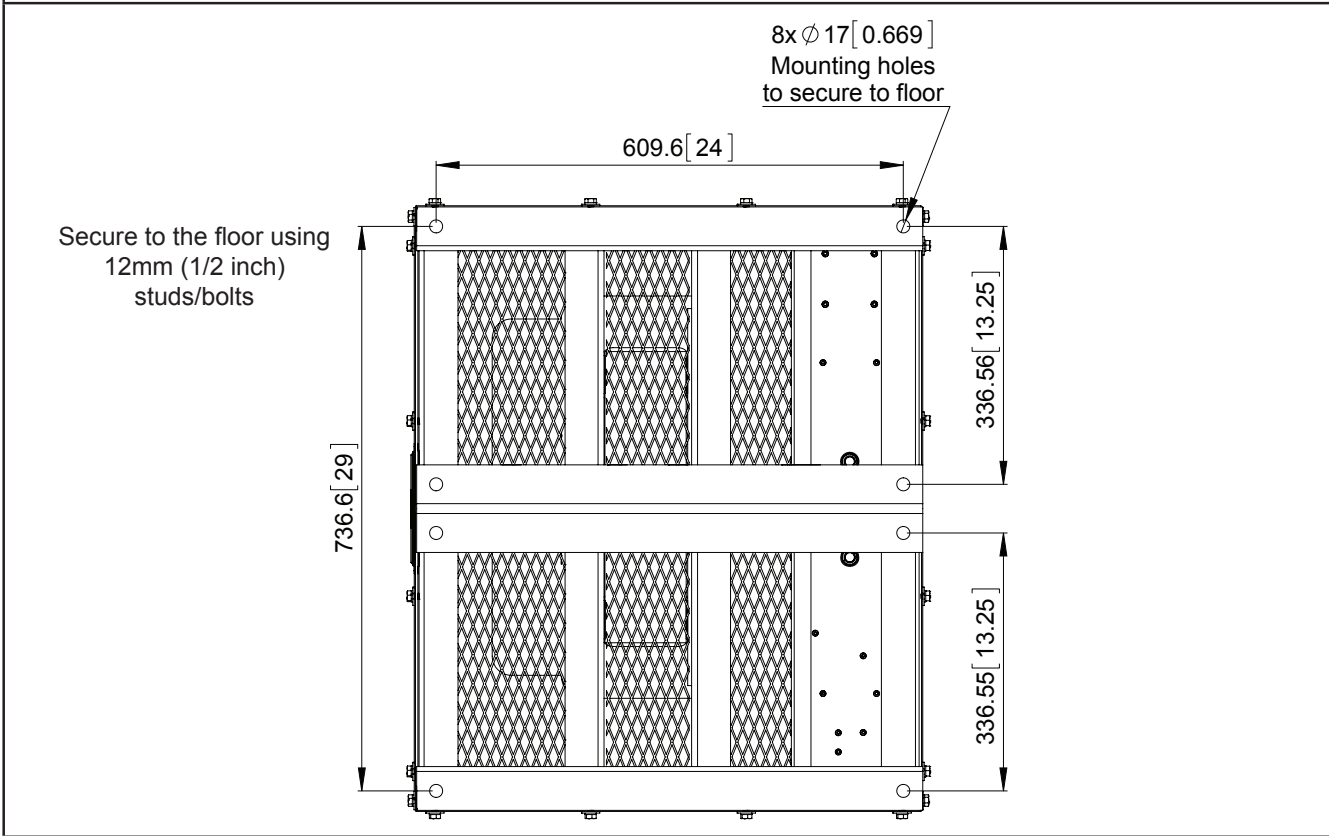

Figure 2.5.4 - Top View - dimensions mm [in]

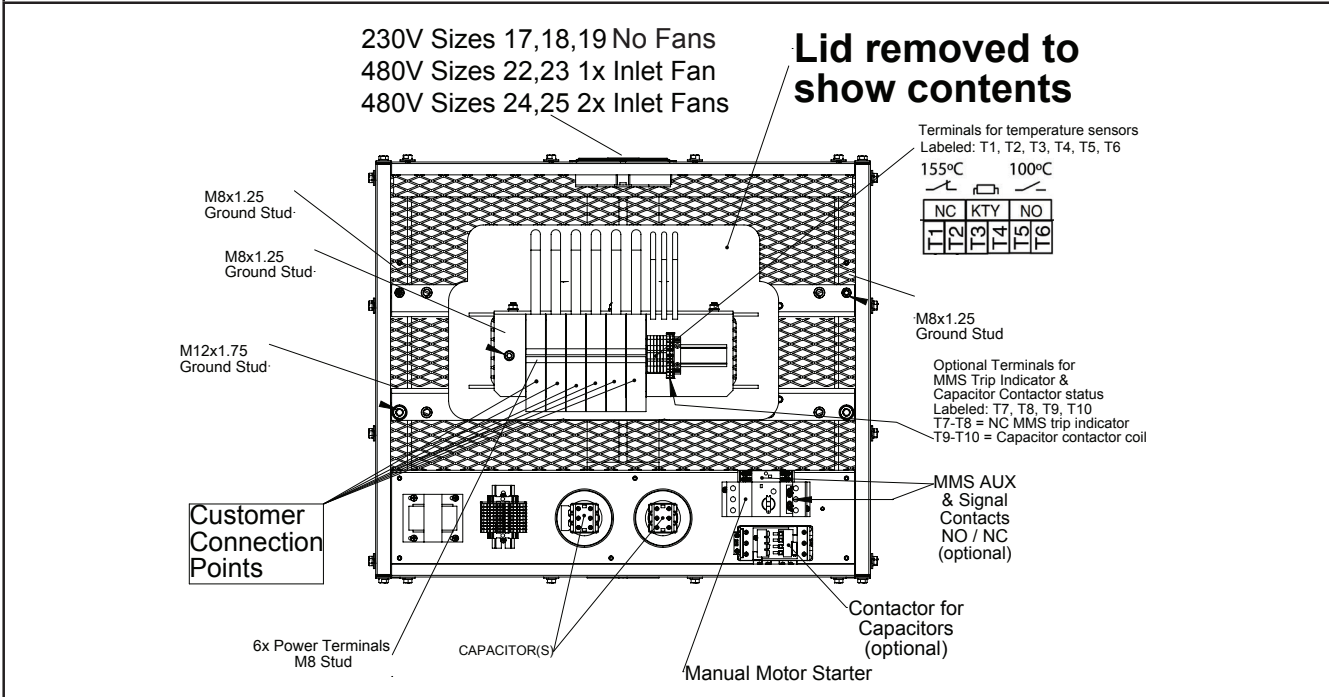

Figure 2.5.5 - Front View - dimensions mm [in]

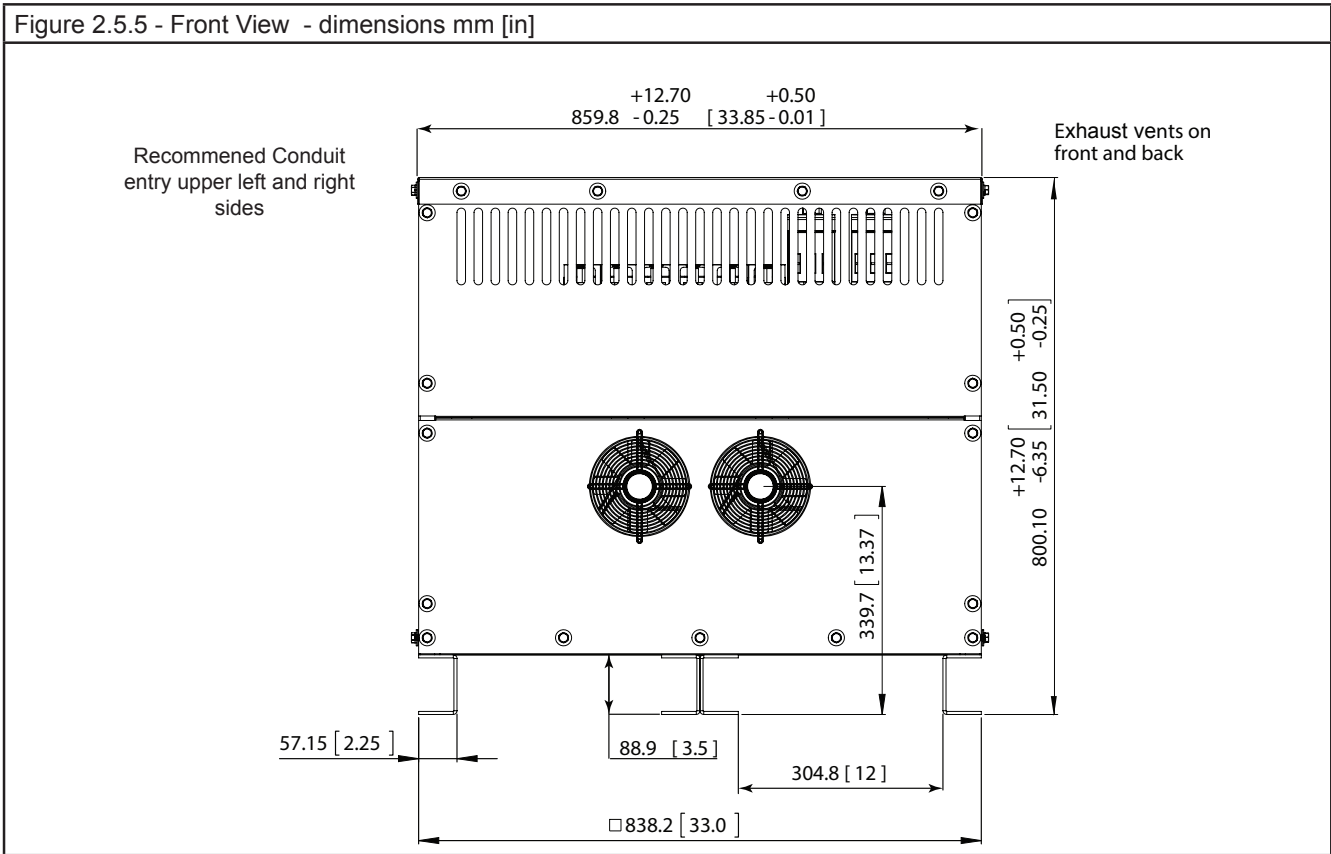
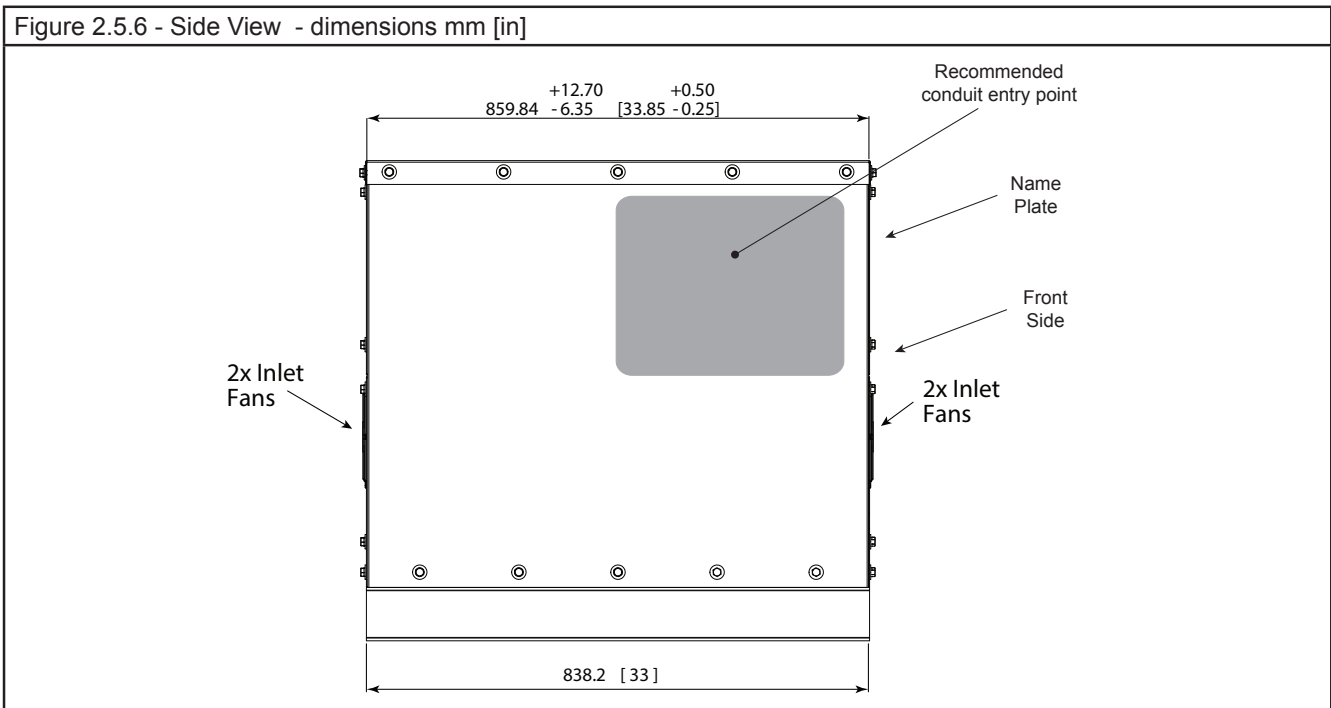

Figure 2.5.6 - Side View - dimensions mm [in]



# Unit Description

Figure 2.5.7 - Bottom View - dimensions mm [in]

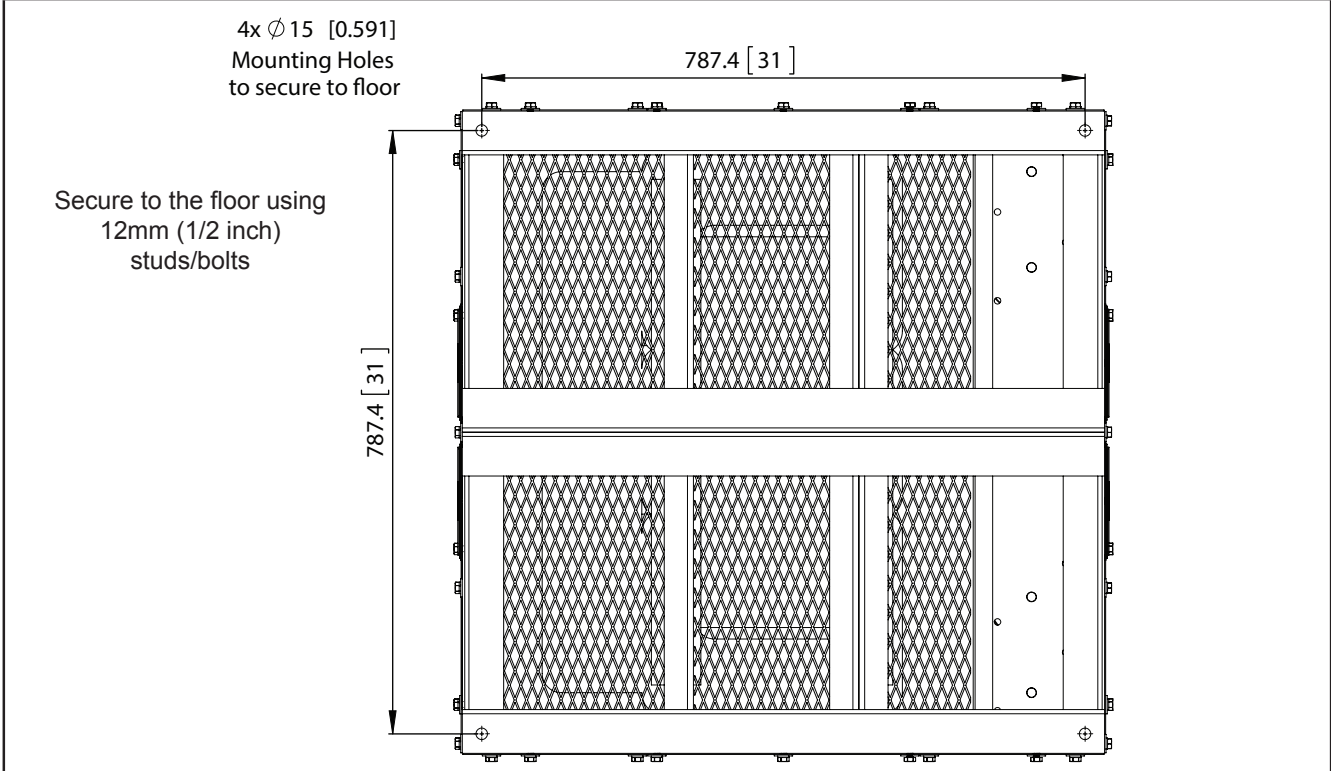
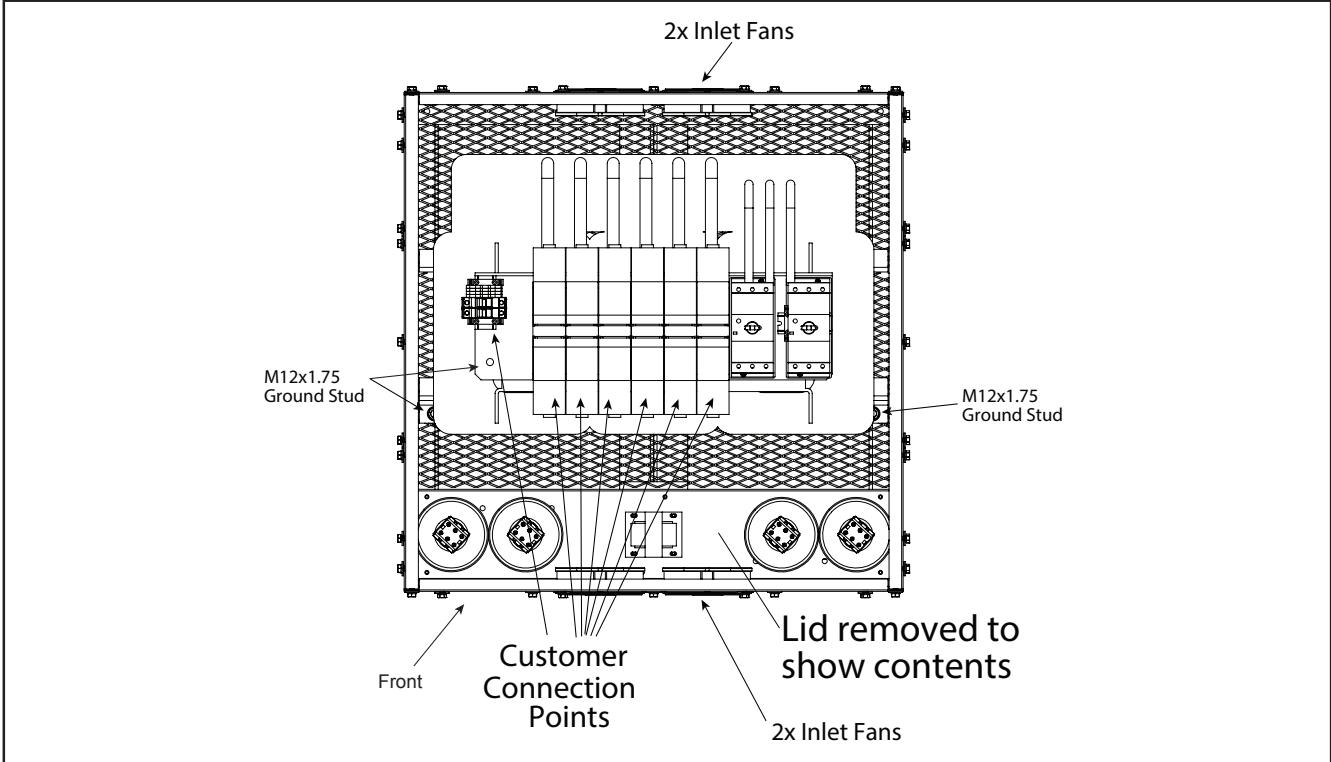

Figure 2.5.8 - Top View - dimensions mm [in]





### 3. Installation NEMA1 Units

#### 3.1 Inductive Core Installation Instructions

The KEB harmonic filter is classified as a NEMA1 device and must be installed in a suitable environment. During installation pay attention to the following:	
•	The filter shall be installed indoors and be protected from any form of falling liquid or liquid spray.
•	When operating continuously at rated load the filter will become hot. Care should be taken that adequate ventilation is provided in the room in which the unit is mounted.
•	The maximum ambient temperature may not be exceeded at continuous rated load.
•	Do not mount the unit in such a way so as to obstruct the cooling fans or vents.
•	Provide clearance to other devices or walls around the unit. Minimum clearances are listed below. Back and left and right sides minimum 30 cm (12 in) Front minimum 90 cm (3 ft)
•	The enclosure shall be transported using a forklift or other device capable of hoisting from beneath.
•	The filter shall be securely mounted on a flat level floor using 12 mm (1/2 in) bolts or studs.
•	Maximum wire length of 5 m (16.5ft) between harmonic filter and connected motor control may not be exceeded. Contact KEB if longer lengths are required.
•	Do not install the filter in an environment having a high level of airborne contamination or particulate. The pollution degree level is Pollution Degree 2.
•	If any part of the enclosure is deformed ( e.g. damaged in transport), the protection of the filter inside may be compromised. In this case do not energize the filter! Contact KEB for replacement panels.

#### 3.2 Electrical Connection

•	Wire the filter to NFPA 70 Class 1 requirements. Use the recommend wire gauges from tables 2.2 and 3.2. Use 600V UL or CSA listed 75°C copper conductors with UL or CSA listed ring terminals where applicable.
•	Tighten the terminal connections to the torques specified in tables 2.2 and 3.2.
•	Branch circuit protection must be provided and shall have a rating of not more than 150% of the rated filter current or the recommended rating of the connected AC motor control, whichever is lower.
•	The recommend branch circuit protection device is a UL 489 listed MCCB 3 phase circuit breaker. As this will clear all three phases at once. Alternately, if fuses must be used, UL 248 listed TYPE J fast acting fuses must be used.
•	 It is necessary to provide supplemental protection to the connected AC motor control. Class J high speed fuses shall be placed between the harmonic filter and the AC motor control. The recommended fuse in this case is MERSEN HSJ "High Speed J". Refer to diagrams 3.2.1 to 3.2.4.
•	 In case the filter is connected to a COMBIVERT R6 regenerative unit, supplemental protection between the filter and the COMBIVERT R6 is mandatory. Class J high speed fuses shall be placed between the harmonic filter and the R6 Regen unit. The recommended fuse in this case is MERSEN HSJ "High Speed J". Refer to diagrams 3.2.1 to 3.2.4.
•	The over heat temperature sensor must wired to the VFD in such a way so as to cause the VFD to switch off in case the sensor indicates high temperature by opening. The sensor must be wired using NFPA 70 Class 2 requirements.
•	The optional auxiliary contacts on the capacitor MMS units may be wired to the machine control for monitoring. These contacts must be wired according to NFPA 70 class 2 requirements.
•	The optional capacitor contactor(s) must be wired to the machine control for activation. These contacts must be connected to a 120VAC branch circuit fused a no more than 15A and wired according to NFPA 70 class 1 requirements.

# Installation

## 3.2.1 Harmonic Filter NEMA1 version (-4000 series)

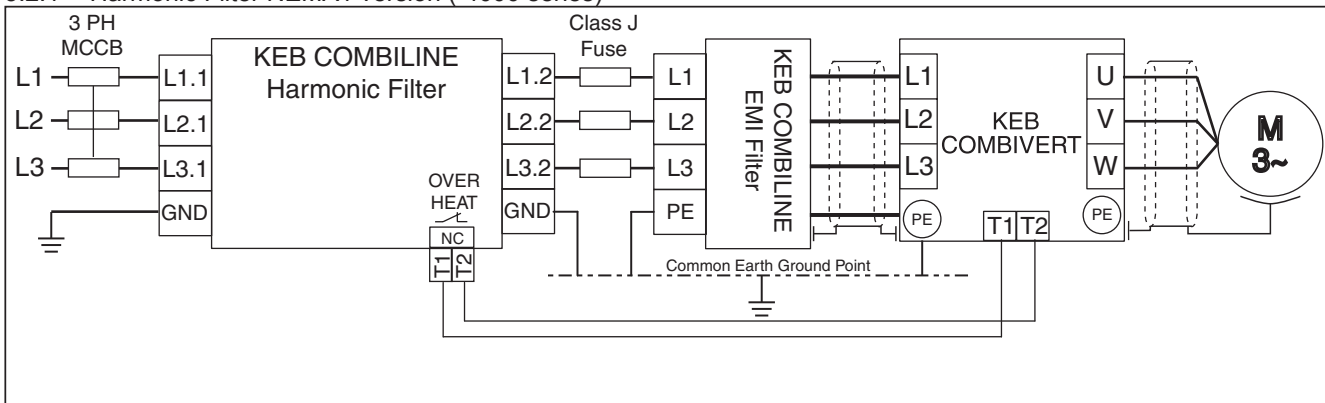

## 3.2.3 Harmonic Filter NEMA1 version -4001 with MMS auxiliary contacts

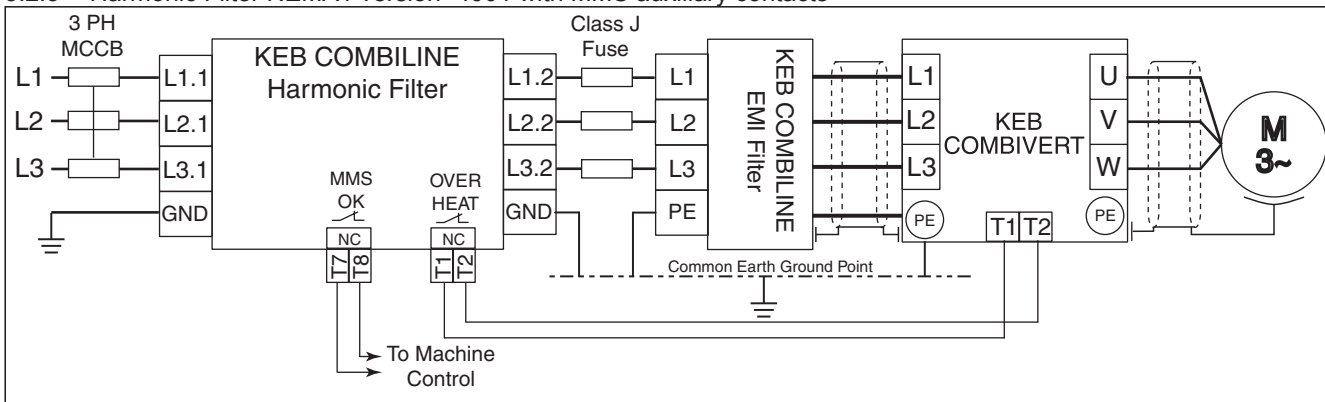

## 3.2.4 Harmonic Filter NEMA1 version -4010 with capacitor contactor(s)

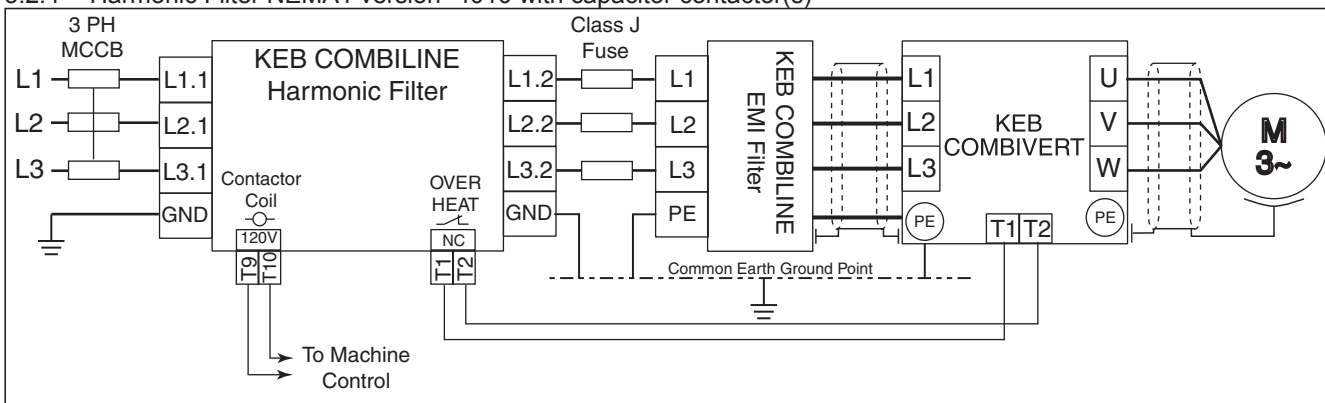



3.2.4 Harmonic Filter NEMA1 version -4011 with MMS auxiliary contacts and capacitor contactor(s)

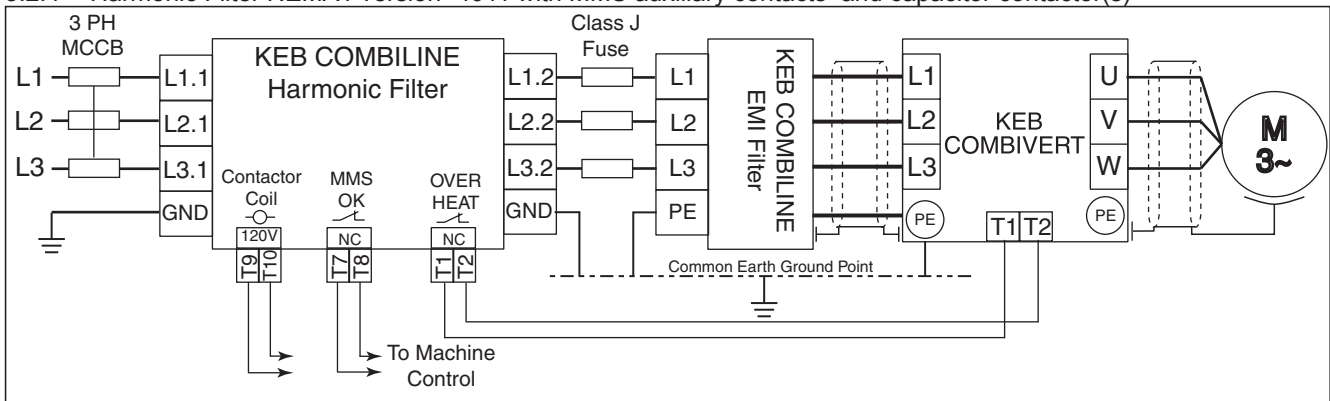

3.3 Temperature Sensors

- T1/T2: is the over heat cut out switch and will open when the maximum winding temperature is reached. It should be connected to T1/T2 on the KEB COMBIVERT and the overheat alarm on the COMBIVERT shall be enabled. Consult the COMBIVERT instructions for details. The contact rating is 230VAC / 2A pilot duty. This can also be monitored by a PLC input as the sensor is double insulated from the high voltage in the core.

3.4 Cooling Fans

- The cooling fans are automatically switched on when the winding temperature reaches 100°C. Failure of one or more fans will result in an overheat condition on the filter. The fans should be checked annually for blocking debris and proper operation. The fan lifetime is rated for 50,000 hours. The fans should be exchanged at this point.

# Installation

## 3.5 Example Schematic Diagram

The exact schematic for each filter size will vary. However it will be provided together with the filter in addition to this instruction manual.

### Service parts list

Order Number	Qty	Description	Supplier	Manu	DT List
CONTACT KEB	4	FILTER CAP	KEB		CAP129;CAP131;CAP134;CAP136
SJ25-058W	1	RELAY SOCKET		IDEC	GR128
RJ25-C-A120	1	RELAY		IDEC	CR128
S915PC-121-B30-A00	4	FAN		NMB	FAN132;FAN134...FAN136
USCC2	1	FUSE HOLDER		MERS	FU126
ATOR1	2	FUSE, CC		MERS	FU126
MS495-75	2	MMS		ABB	MMS132;MMS137
3209578	6	TERM. ST		PHX	TB3;TB4
3209594	3	TERM. ST GND		PHX	TB3;TB4
SP150MOMJ	1	TRANSFORMER		HPS	TR126
3021C15-1000	1	FILTER CORE	KEB		UI04

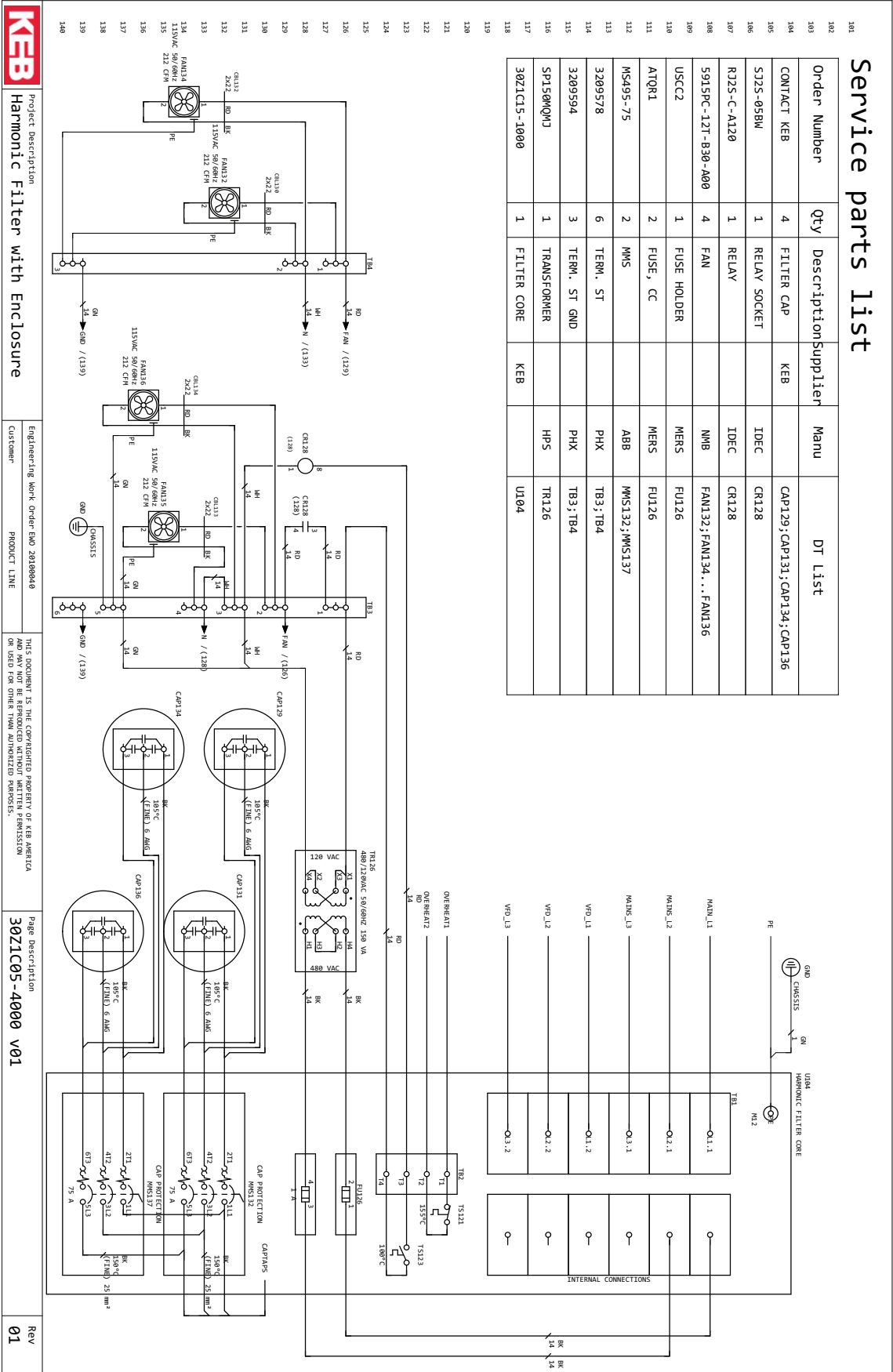

**KEB** Project Description: Harmonic Filter with Enclosure  
 Engineering Work Order: EMO 20300040  
 Customer: \_\_\_\_\_  
 Product Line: \_\_\_\_\_  
 This document is the copyrighted property of KEB America or used for other than authorized purposes.  
 Page Description: 3021C05-4000 v01  
 Rev: 01

## 4. Example waveforms

### 4.1 Voltage and current at the main line

Without a line choke high current peaks (5 to 10 times the rms value) occur resulting in a high ripple current in the DC bus of the motor control. This also means higher ripple voltage on the DC bus which can lead to torque ripple or reduced torque output from the motor.

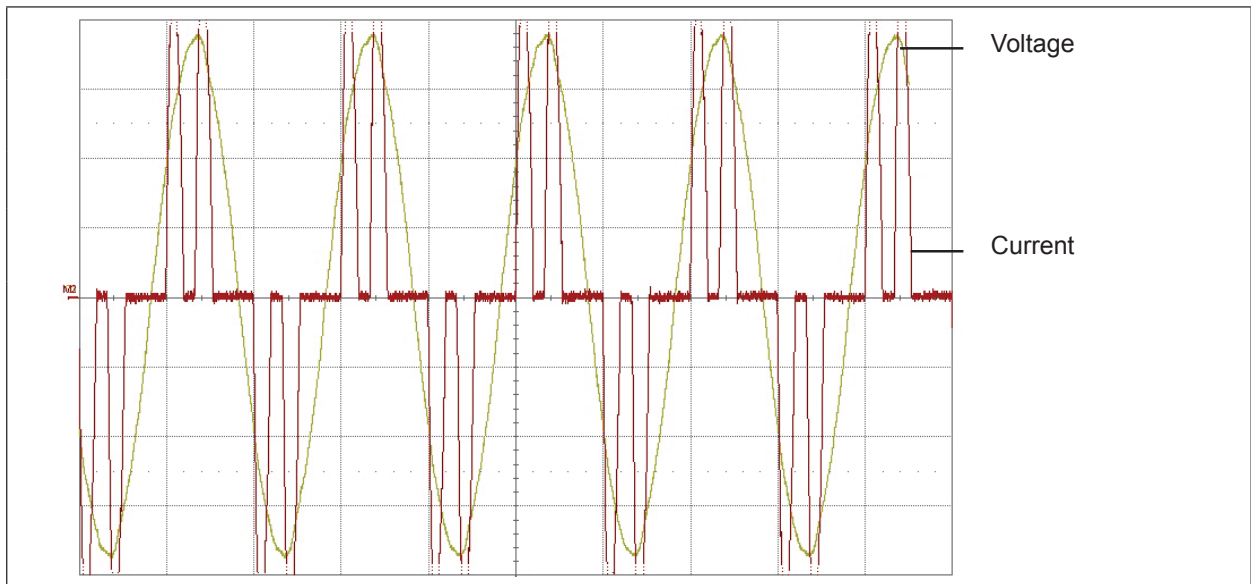

### 4.2 Voltage and current with line choke impedance = 3% 480V/60Hz (4% 400V/50Hz)

With inductance (line choke) the peak amplitude of the current is reduced to a range of 3 to 5 times the rms value. This means lower ripple current in the DC bus of the motor control. This reduces heating in the capacitors and effectively extends the lifetime by a factor of two.

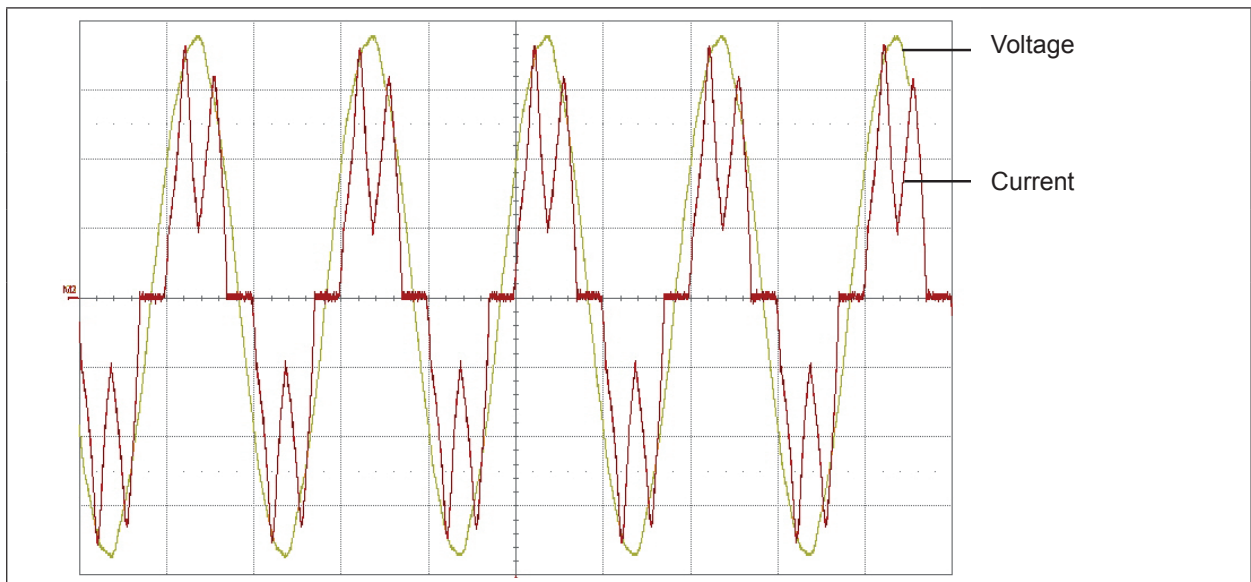

## Waveforms

### 4.3 Voltage and current with the harmonic filter THDI < 8%

With the harmonic filter, the line-side current is sinusoidal. The peak amplitude of the current is 1.4 times the rms value. The output of the filter provides a nearly ideal rectangular voltage and current waveform into the motor control resulting in diode conduction of almost 180 degrees. The voltage on the DC bus is practically flat and the DC bus capacitors see minimum ripple current. This results in a further extension of life to 3+ times the nominal. Furthermore the average voltage value of the DC bus does not sag much in comparison to the first two cases. The result is more motor torque at higher speeds.

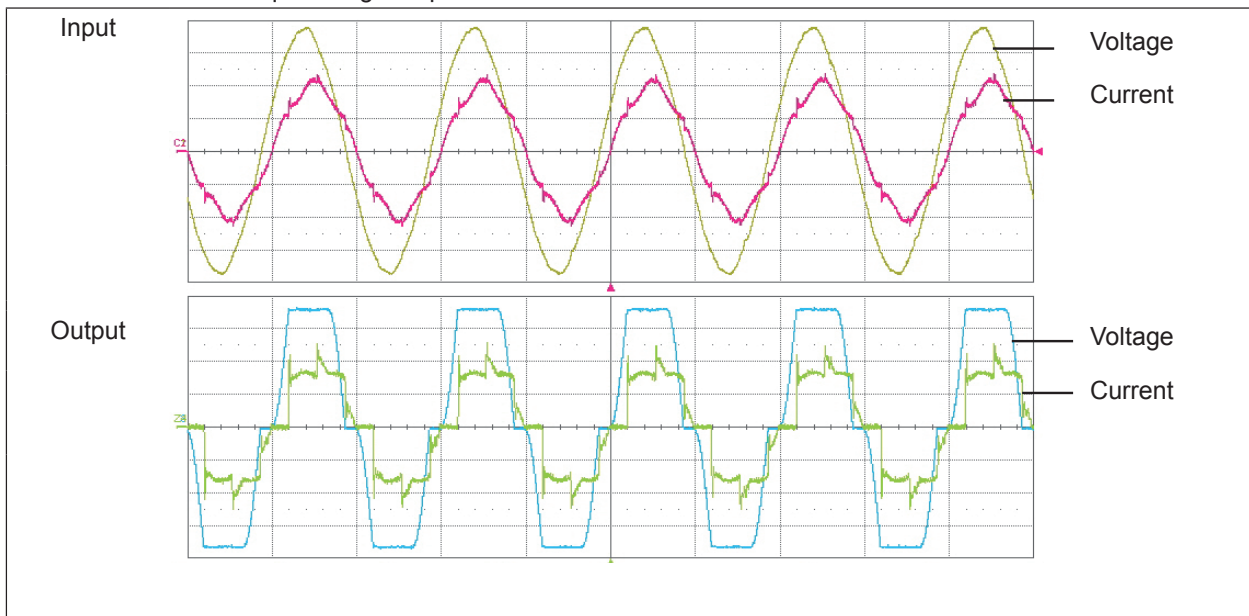

## 5. Annex

### 5.1 Fourier Analysis / Spectrum

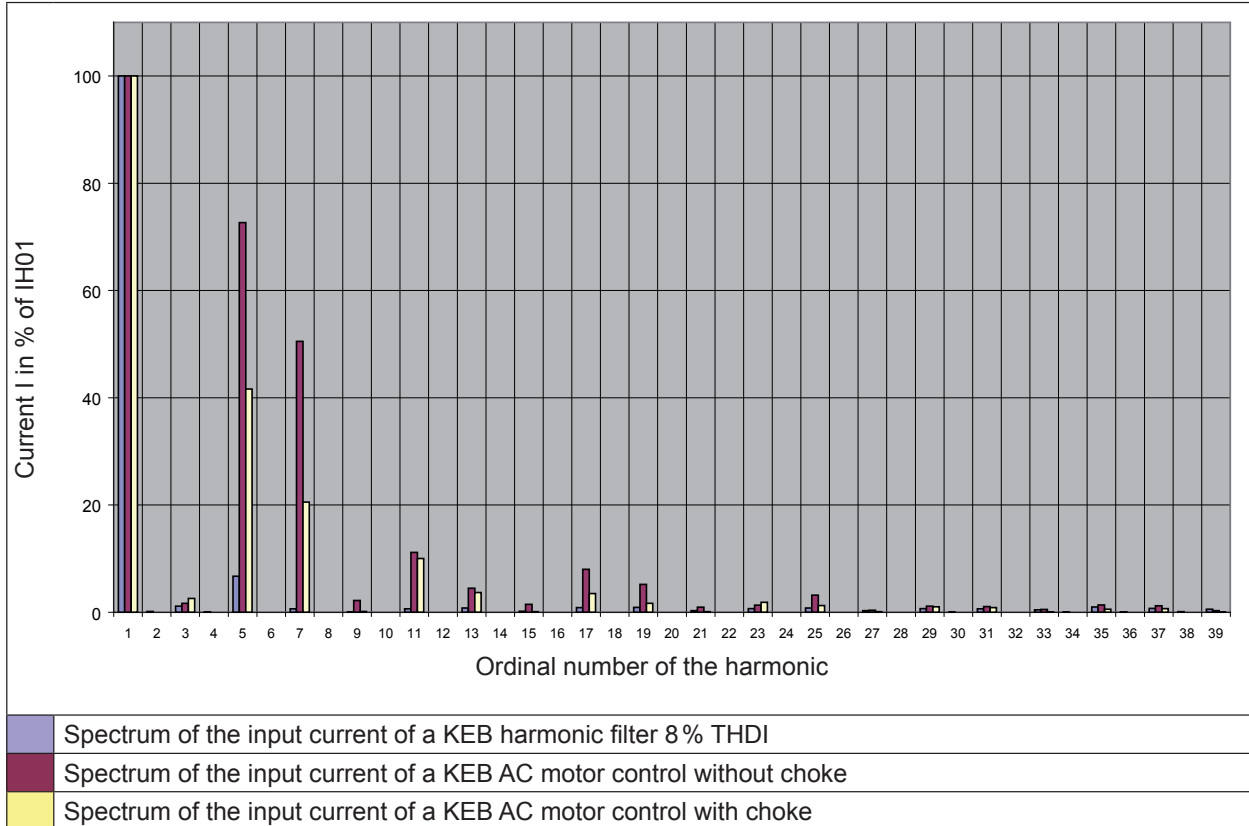

### 5.2 Formula and Abbreviations

THD (Total Harmonic Distortion) 
$$THD = \sqrt{\sum_{n=2}^{40} \left(\frac{I_n}{I_1}\right)^2}$$

THDV (Total Harmonic Distortion Voltage)  
 THDI (Total Harmonic Distortion Current)

PWHD (Partial Weighted Harmonic Distortion) 
$$PWHD = \sqrt{\sum_{n=14}^{40} n \left(\frac{I_n}{I_1}\right)^2}$$

$S_{rtd}$  (Rated Apparent Power of the Equipment) 
$$S_{rtd} = \sqrt{3} * V_{Line} * I_L$$

$R_{sce}$  (Short-circuit Ratio) 
$$R_{sce} = \frac{S_{sc}}{S_{rtd}}$$

$I_{sc}/I_L$  (Short-circuit current Ratio) 
$$I_{sc}/I_L = \frac{I_{sc}}{I_L}$$

5.3 Representative Performance Curves

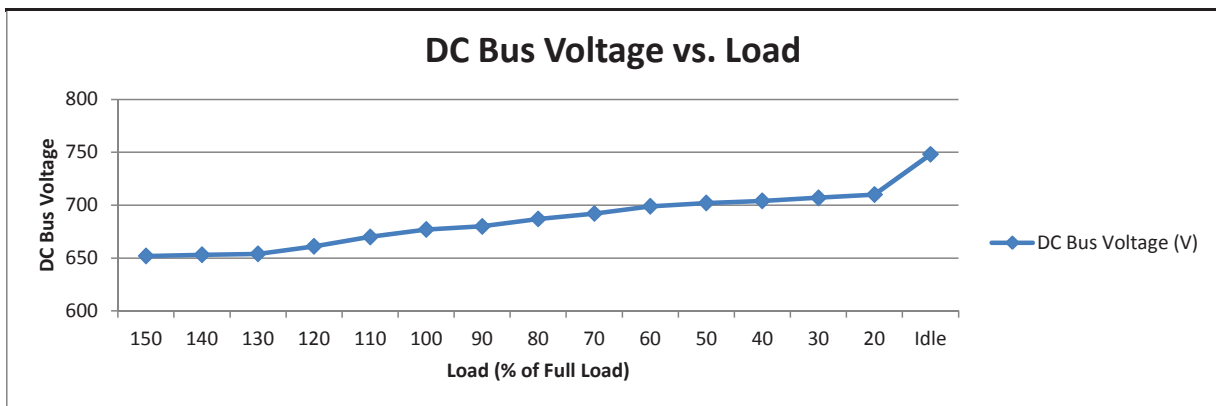
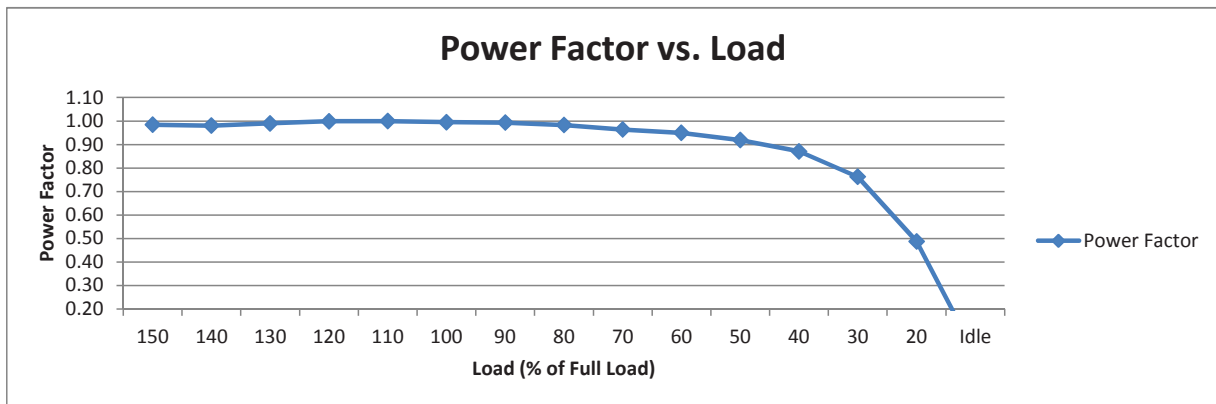
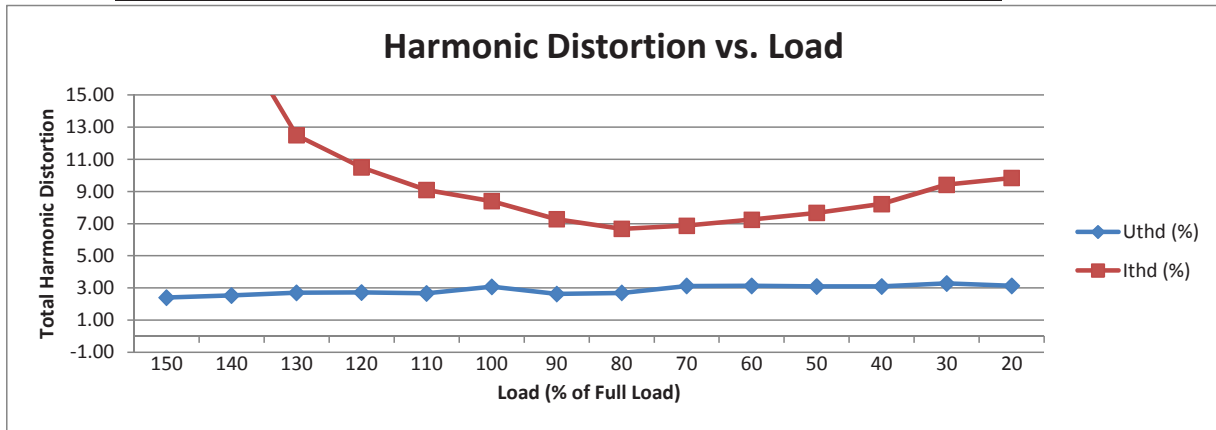

#### 5.4 Product Certification

The following marks on the device indicate compliance with the following standards.

	230V sizes 17-19, 480V sizes 22-30 Indicates Investigated to Canadian National Standard, C22.2 No. 14-2012. Indicates Investigated to United States Standard, UL 508, 17th Edition.
---	---



## KEB Automation KG

Försterweg 36-38 • D-32683 Barntrup  
fon: +49 5263 401-0 • fax: +49 5263 401-116  
net: [www.keb.de](http://www.keb.de) • mail: [info@keb.de](mailto:info@keb.de)

## KEB worldwide...

**KEB Antriebstechnik Austria GmbH**  
Ritzstraße 8 • A-4614 Marchtrenk  
fon: +43 7243 53586-0 • fax: +43 7243 53586-21  
net: [www.keb.at](http://www.keb.at) • mail: [info@keb.at](mailto:info@keb.at)

**KEB Antriebstechnik**  
Herenveld 2 • B-9500 Geraadsbergen  
fon: +32 5443 7860 • fax: +32 5443 7898  
mail: [vb.belgien@keb.de](mailto:vb.belgien@keb.de)

**KEB Power Transmission Technology (Shanghai) Co.,Ltd.**  
No. 435 Qianpu Road, Chedun Town, Songjiang District,  
CHN-Shanghai 201611, P.R. China  
fon: +86 21 37746688 • fax: +86 21 37746600  
net: [www.keb.de](http://www.keb.de) • mail: [info@keb.cn](mailto:info@keb.cn)

**KEB Antriebstechnik Austria GmbH**  
Organizační složka  
K. Weise 1675/5 • CZ-370 04 České Budějovice  
fon: +420 387 699 111 • fax: +420 387 699 119  
mail: [info.keb@seznam.cz](mailto:info.keb@seznam.cz)

**KEB Antriebstechnik GmbH**  
Wildbacher Str. 5 • D-08289 Schneeberg  
fon: +49 3772 67-0 • fax: +49 3772 67-281  
mail: [info@keb-drive.de](mailto:info@keb-drive.de)

**KEB España**  
C/ Mitjer, Nave 8 - Pol. Ind. LA MASIA  
E-08798 Sant Cugat Sesgarrigues (Barcelona)  
fon: +34 93 897 0268 • fax: +34 93 899 2035  
mail: [vb.espana@keb.de](mailto:vb.espana@keb.de)

**Société Française KEB**  
Z.I. de la Croix St. Nicolas • 14, rue Gustave Eiffel  
F-94510 LA QUEUE EN BRIE  
fon: +33 1 49620101 • fax: +33 1 45767495  
net: [www.keb.fr](http://www.keb.fr) • mail: [info@keb.fr](mailto:info@keb.fr)

**KEB (UK) Ltd.**  
Morris Close, Park Farm Industrial Estate  
GB-Wellingborough, NN8 6 XF  
fon: +44 1933 402220 • fax: +44 1933 400724  
net: [www.keb.co.uk](http://www.keb.co.uk) • mail: [info@keb.co.uk](mailto:info@keb.co.uk)

**KEB Italia S.r.l.**  
Via Newton, 2 • I-20019 Settimo Milanese (Milano)  
fon: +39 02 3353531 • fax: +39 02 33500790  
net: [www.keb.de](http://www.keb.de) • mail: [kebitalia@keb.it](mailto:kebitalia@keb.it)

**KEB Japan Ltd.**  
15-16, 2-Chome, Takanawa Minato-ku  
J-Tokyo 108-0074  
fon: +81 33 445-8515 • fax: +81 33 445-8215  
mail: [info@keb.jp](mailto:info@keb.jp)

**KEB Korea Seoul**  
Room 1709, 415 Missy 2000  
725 Su Seo Dong, Gang Nam Gu  
ROK-135-757 Seoul/South Korea  
fon: +82 2 6253 6771 • fax: +82 2 6253 6770  
mail: [vb.korea@keb.de](mailto:vb.korea@keb.de)

**KEB RUS Ltd.**  
Lesnaya Str. House 30, Dzerzhinsky (MO)  
RUS-140091 Moscow region  
fon: +7 495 632 0217 • fax: +7 495 632 0217  
net: [www.keb.ru](http://www.keb.ru) • mail: [info@keb.ru](mailto:info@keb.ru)

**KEB America, Inc.**  
5100 Valley Industrial Blvd. South  
USA-Shakopee, MN 55379  
fon: +1 952 224-1400 • fax: +1 952 224-1499  
net: [www.kebamerica.com](http://www.kebamerica.com) • mail: [info@kebamerica.com](mailto:info@kebamerica.com)

More information can be found at [www.keblog.com](http://www.keblog.com) or [www.kebamerica.com](http://www.kebamerica.com)

© KEB	
Document	20141310
Part/Version	USA 01
Date	2020-10-21