

Calculation power of motor

Overview of GD²

1. Motor and Inertia Load

- The equation to calculate the torque that is required for the motor to make the inertia load start rotating is as follows.

$$T = J\alpha = J \cdot \frac{d\omega}{dt} = \frac{GD^2}{4g} \cdot \frac{d\omega}{dt} = \frac{2\pi}{60} \cdot \frac{GD^2}{4g} \cdot \frac{dn}{dt}$$

T : TORQUE

J : Inertia moment

ω : Angular velocity, t : Time

n : Rotational velocity

GD² : FLYWHEEL effect [GD² = 4gJ]

g : Gravitational acceleration (g = 9.8[m/sec²])

α : Angular acceleration

- In case of an induction motor, the starting torque will be changed by rotating speed.
- The average value from the starting speed to the normal constant speed is called an average acceleration torque, a value commonly used in practice.

- The average acceleration torque TA required for the inertia load GD² to be accelerated up to the speed n[r/min] within t[sec] is represented by the following equation.

$$TA = \frac{GD^2}{37500} \times \frac{n}{t} \text{ [kgf} \cdot \text{cm]}$$

2. Calculation of Flywheel Effect [GD²]

- In case that a load is acquired through the connection of a gearhead, the motor shaft component of the load inertia should be calculated to select the motor.
- Also, the calculation method of GD² differs depending on the type of a load, and the following equation provides GD² calculation method for each shape.

$$GD^2 = 4J \text{ [kgf} \cdot \text{cm}^2]$$

GD² : FLYWHEEL effect

J : Inertia moment

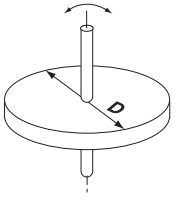
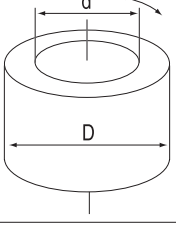
	Circular Disk	Hollow
Shape		
GD ² Equation	$GD^2 = \frac{1}{2} WD^2$ [kgf · cm ²] W : Mass [kgf] D : Outer Diameter [cm]	$GD^2 = \frac{1}{2} W(D^2+d^2)$ [kgf · cm ²] W : Mass [kgf] d : Inner Diameter [cm] D : Outer Diameter [cm]

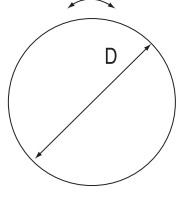
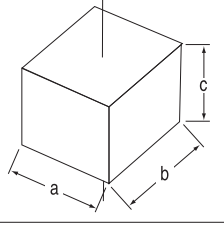
	Sphere	Hexahedron
Shape		
GD ² Equation	$GD^2 = \frac{2}{5} WD^2$ [kgf · cm ²] W : Mass [kgf] D : Diameter [cm]	$GD^2 = \frac{1}{3} W(a^2+b^2)$ [kgf · cm ²] W : Mass [kgf] a, b : Length of Side [cm]

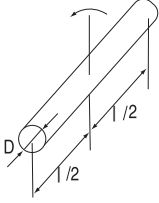
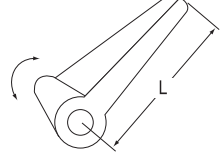
	POLE	POLE
Shape		
GD ² Equation	$GD^2 = W(\frac{D^2}{4} + \frac{l^2}{3})$ [kgf · cm ²] W : Mass [kgf] D : Outer Diameter [cm] l : Length [cm]	$GD^2 = \frac{4}{3} WL^2$ [kgf · cm ²] W : Mass [kgf] l : Length [cm]

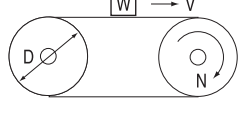
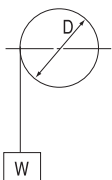
	Linear Motion(Horizontal)	Linear Motion(Vertical)
Shape		
GD ² Equation	$GD^2 = WD^2$ [kgf · cm ²] = $\frac{WV^2}{\pi^2 N^2}$ V : CONVEYOR SPEED [cm/min] N : DRUM ROTATIONAL SPEED [rpm] W : WEIGHT OVER CONVEYOR [kgf] D : DRUM OUTSIDE Diameter[cm] (Not included GD ² for belt and drum)	$GD^2 = WD^2$ [kgf · cm ²] W : Mass[kgf] D : Diameter[cm]

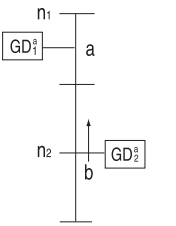
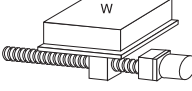
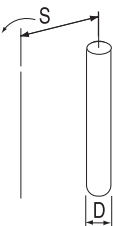
	Gearhead	Operation of ball screw	GD ² of arbitrary shaft
Shape			
GD ² Equation	a axis component of total GD ² $GD_a^2 = GD_1^2 + (\frac{n_2}{n_1})^2 \times GD_{22}$ [kgf · cm ²] n ₁ : Rotational speed of a-axis n ₂ : Rotational speed of b-axis Reduction ratio is $\frac{n_1}{n_2}$ (i>1)	$GD^2 = GD_1^2 + \frac{WP^2}{\pi}$ GD ₁ ² : GD ² of BALL SCREW GD [kgf · cm ²] P : PITCH of BALL SCREW[cm] W : Total weight of table and work	$GD^2 = GD^2 + 4WS^2$ [kgf · cm] D : Diameter [cm] W : Mass [kgf] S : Radius of Rotation [cm]

• The table below shows the permissible inertia load per motor. Do not use to exceed the figure shown.

• Permissible Inertia Load per Motor Axis

SIZE	Output	Permissible Inertia Load per Motor Axis GD ² (kgf-cm ²)
□60	3W	0.19
□60	6W	0.25
□70	15W	0.57
□80	15W, 25W	1.20
□90	40W	3.00
□90	60W	4.60
□90	90W, 120W, 150W	4.60
□90	180W, 200W	6.00

Gear ratio between 1/3 ~ 1/50 : GD²_G = GD²_M × i²
 Gear ratio over 1/60 : GD²_G = GD²_M × 2500
 GD²_G : Permissible inertia per gearhead output
 GD²_M : Permissible inertia per motor Axis
 i : Gear ratio

Explicit Calculation Method of Motor Capacity

- The following explanations describe how the required capacity for a motor can be calculated. These are basic equations in a general circumstance.
- Hence, when selecting a motor, the following points should be taken into consideration. The acceleration at starting time, the power required for a large load imposed instantaneously,, or the safety measures implemented at design and manufacturing levels, and the impact of changing voltage.

(1) In case of rolling up a load

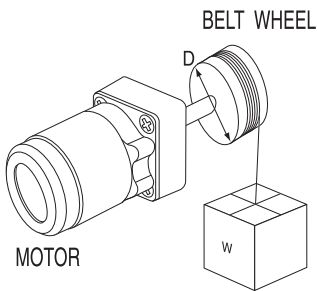

$$T = \frac{1}{2} D \cdot W \text{ [kgf} \cdot \text{m]}$$

D : Drum Diameter [m]
W : Weight [kgf]

(2) In case of operation inertia mass

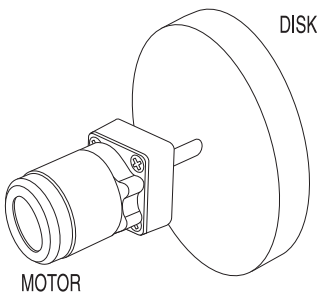

$$T = \frac{GD^2}{37500} \times \frac{N}{t} \text{ [kgf} \cdot \text{m]}$$

N : Revolutions per minute [rpm]
GD² : Disk wheel effect [kgf · cm²]
t : Time [sec]

(3) In case of belt conveyor

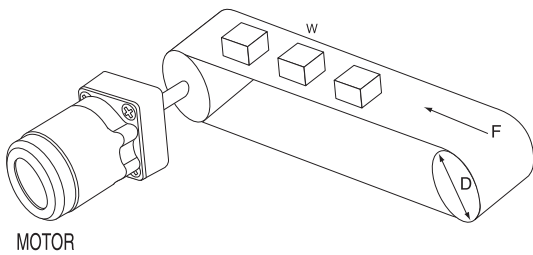

$$T = \frac{1}{2} D(F + \mu W) \text{ [kgf} \cdot \text{m]}$$

D : Drum의 Diameter [m]
w : Mass of belt in unit length [kgf]
 μ : Coefficient of friction
F : Cutting force [kgf]

(4) A case of moving an object horizontally on the surface

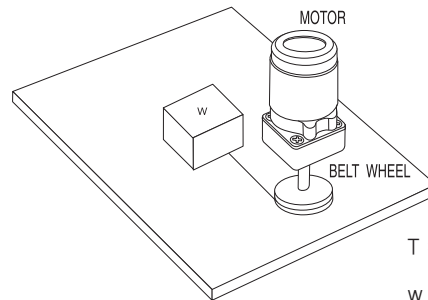

$$T = \frac{1}{2} D \cdot \mu W \text{ [kgf} \cdot \text{m]}$$

w : Weight [kgf]
 μ : Coefficient of friction
D : WHEEL Diameter

(5) In case of driving a ball screw

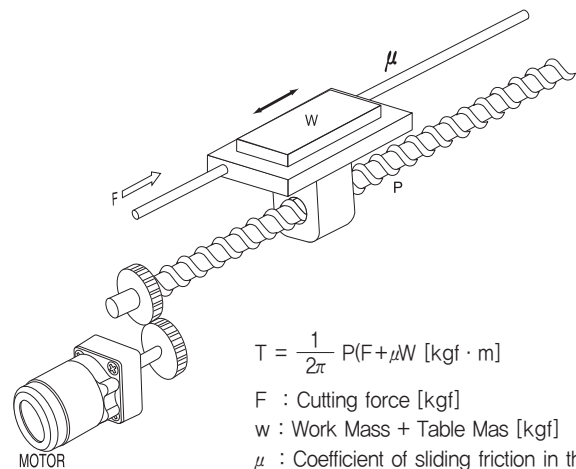

$$T = \frac{1}{2\pi} P(F + \mu W) \text{ [kgf} \cdot \text{m]}$$

F : Cutting force [kgf]
w : Work Mass + Table Mas [kgf]
 μ : Coefficient of sliding friction in the slide guide surface [0.05~0.2]
P : Lead of Ball Screw [m]